



# **MODEL 110**

## **RADIO COMMUNICATION SYSTEM**

### **INSTALLATION & OPERATION MANUAL**





# TABLE OF CONTENTS

Overview .....	2
Features .....	3
Installation .....	4
System Wiring .....	5
Overview .....	5
Power Connections .....	6
CA Cable Routing .....	6
Headset Module Installation .....	6-7
Foot Switch (optional) .....	7
Radio Connections .....	8
Settings .....	8-9
Operation .....	9
Troubleshooting .....	10-11
Options and Accessories .....	12
Specifications .....	12
Appendix A-Wiring Diagrams .....	12-13
Appendix B-RJ-12 Connector Assembly .....	14
Warranty .....	15

## OVERVIEW

Firecom's 110 radio interface is designed for use in rugged, demanding environments. When used with Firecom noise attenuating headsets, the system provides protection from hearing loss that occurs from exposure to high noise levels while offering a 2-way radio communication interface. The 110 radio interface is a durable solution for vehicles and other high-noise environments requiring radio communications.

When properly installed, the user will hear radio traffic and transmit over the radio when the Push-To-Talk (PTT) button is activated.

# FEATURES

### Front View

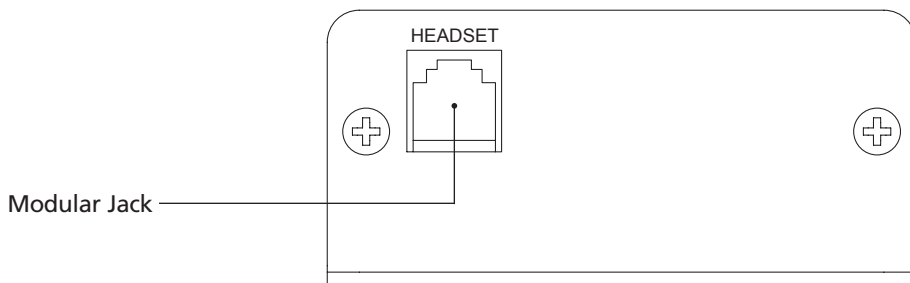

### Back View

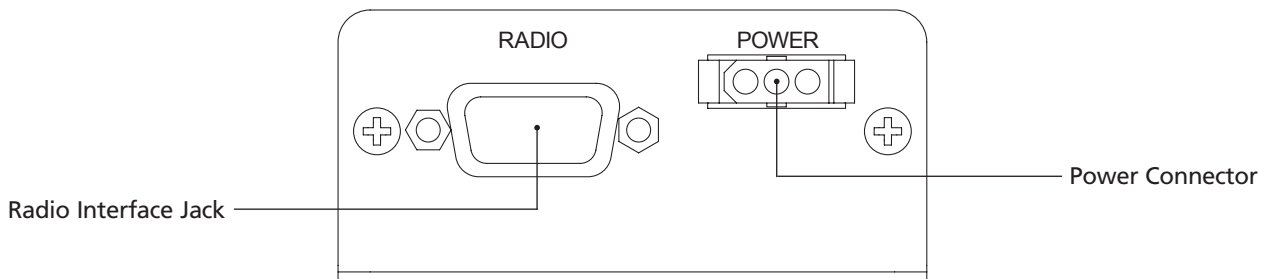

### Side View

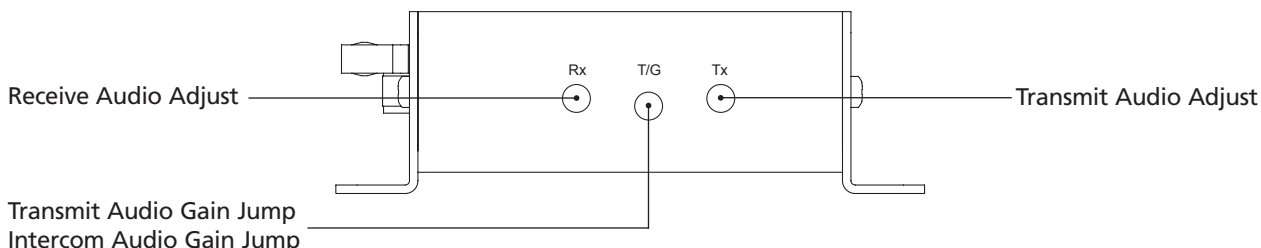

### Modular Jack

The modular jack is the connection point for the CA cable leading from the 110 radio interface to the headset module.

### Radio Interface Jack

The 9-pin D-Sub connector is an attachment point for the included mobile radio (MR) interface cable.

### Power Connector

The 3-pin connector is the attachment point for vehicle power. A power connection cable is provided.

### Receive Audio Adjust

A rotational adjustment for setting the level of audio received to the intercom from a mobile radio.

### Transmit Audio Gain Jump/Intercom Audio Gain Jump

Two dip switches are provided for incremental gain increases of both the radio transmit audio and the intercom audio.

### Transmit Audio Adjust

A rotational adjustment for setting the level of audio transmitted to an appropriate level for a mobile radio.

# INSTALLATION

## Mounting the Radio Interface Unit

Mount the interface unit to a flat surface by drilling four mounting holes and installing the enclosed #6 fasteners. Mounting hole and intercom dimensions are shown below. The unit is designed for vehicle interiors and indoor use. Do not mount outdoors.

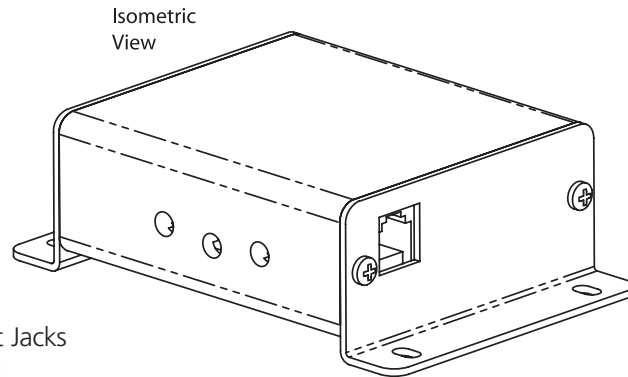

Assembly Shown without Jacks  
Units: Inches [millimeters]  
Scale: None

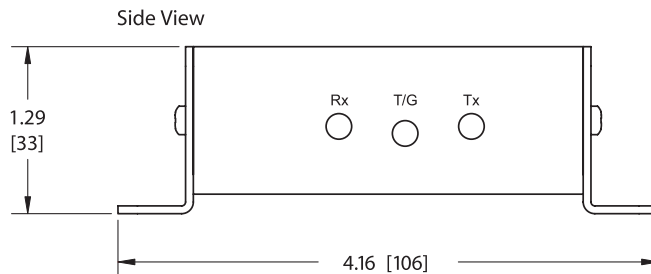
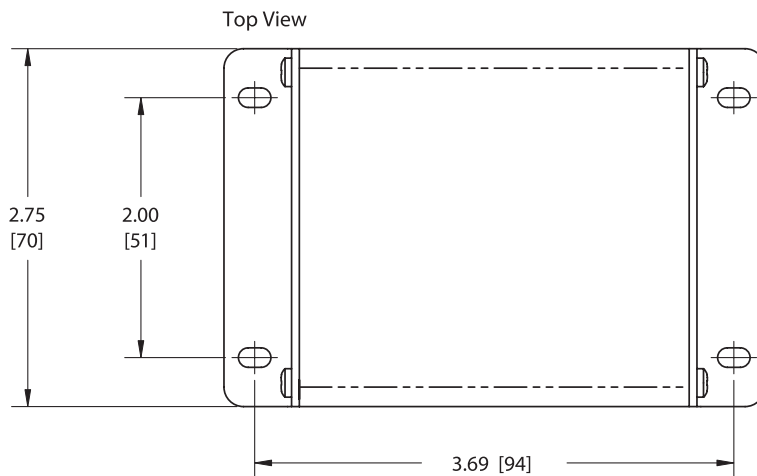

# SYSTEM WIRING

## Overview

Once the radio interface unit is installed, the system is ready for wiring. A headset module can be connected to the headset port using a RJ-12 connector and CA cable as shown in the figure below. See "CA Cable Routing" in the Installation section of this manual before wiring. The 2-way radio is added using the 9-pin D-Sub connector.

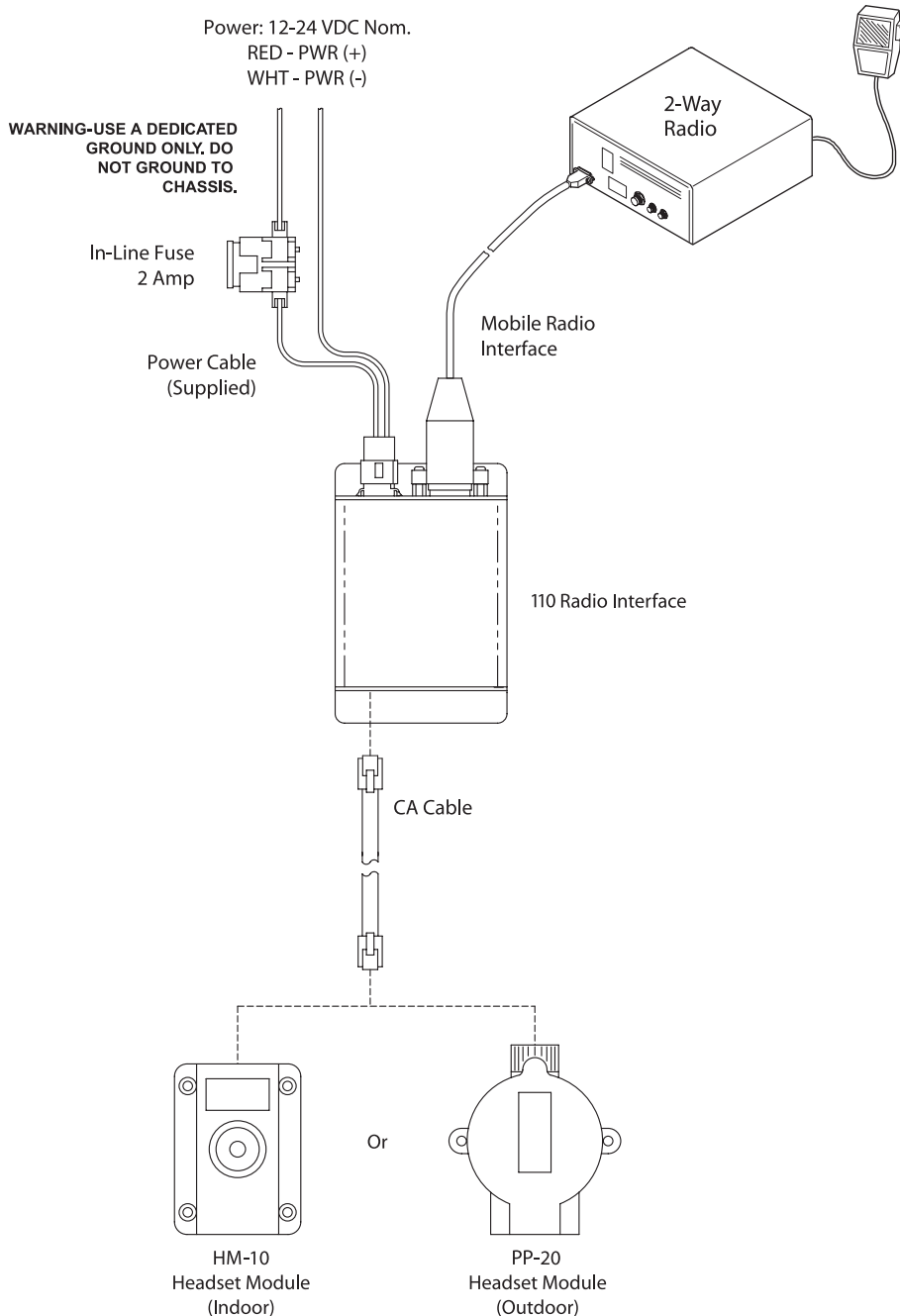

# SYSTEM WIRING

## Power Connections

Power is wired to the unit using the power supply cable with in-line fuse (included). When routing the power cable, the in-line fuse should be easy to access.



### Warning

**Before making power connections, make sure the power source is turned off.**

### Important

**Use a dedicated ground for the (-) power connection. Do not ground to the chassis.**

### Important

**We recommend connecting the intercom power to the same power busses as the 2-way radio.**

## CA Cable Routing

There are several important considerations when routing the CA cable:

- Do not bundle extra cable. The cable should be cut to length at installation, especially when radios are used.
- Route CA cables away from hot surfaces including vehicle exhaust systems.
- When routing CA cables through bulkheads or other sheet metal, use a grommet in the hole to prevent damage to the cable.

## Headset Module Installation

The following steps are recommended for installing a HM-10 or PP-20 headset module.

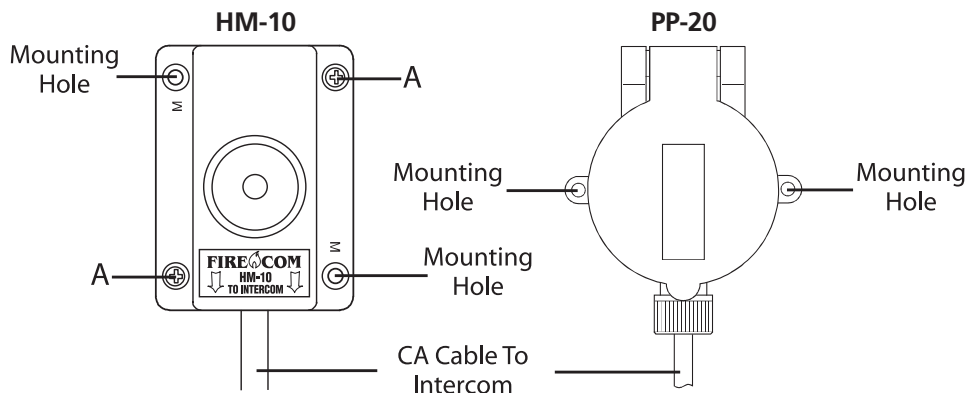

- Identify where the headset module is to be mounted and use the module as a template to locate the two mounting holes as shown in figure above. Drill two holes for the #6 hardware provided.
- If you are installing a PP-20 module, route the CA cable as outlined in “CA Cable Routing” on this page and install an RJ-12 connector at the intercom end of the cable as outlined in Appendix B “RJ-12 Connector Assembly.” **Always make sure the printed side of the cable is facing the release tab on the RJ-12 modular plug.** If you are installing an HM-10 module, continue with the following steps.

## SYSTEM WIRING

### Headset Module Installation

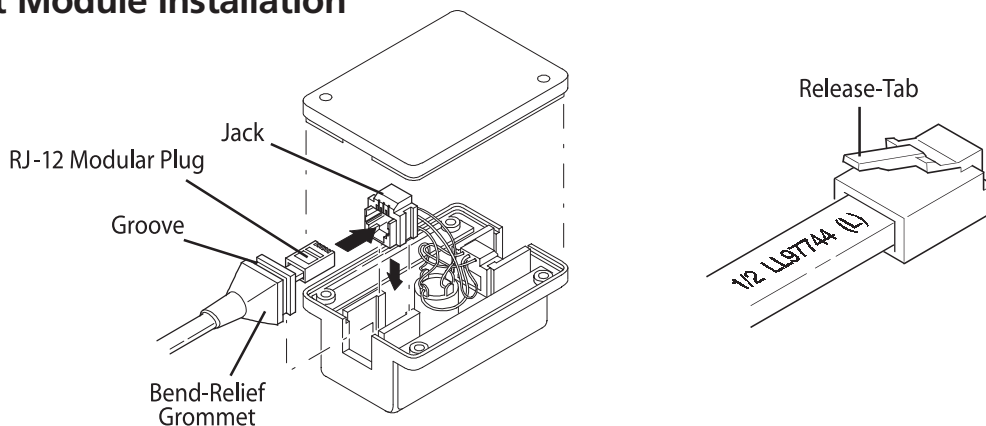

- With the CA cable routed from the intercom, cut the cable to length at the headset module and slide the bend relief grommet over the end of the CA cable as shown in the figure above.
- Attach a RJ-12 connector to the end of the cable –see Appendix B “RJ-12 Connector Assembly.” **Always make sure the printed side of the cable is facing the release tab on the RJ-12 modular plug.**
- Open the headset module assembly by removing the screws labeled “A” in the figure on page 6. Install the plug and bend relief grommet as shown in the figure above. **If the CA cable is going from the intercom to the headset module it MUST be inserted on the same side of the HM-10 as the “Firecom” label.** Replace the headset module cover and mount the assembly with the hardware provided.

### Foot Switch (optional)

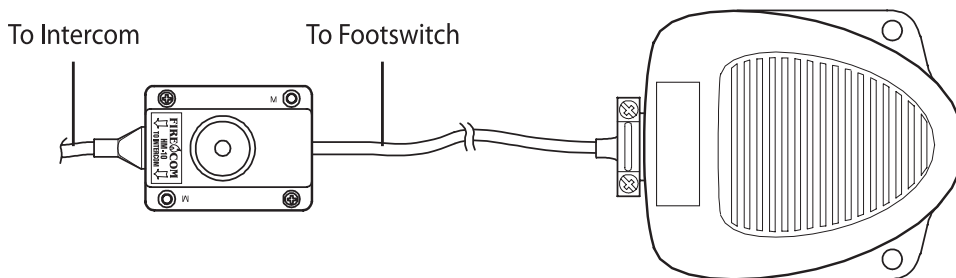

A radio Push-to-Talk (PTT) foot switch option is available from Firecom when a headset radio PTT is not desired. Depressing the foot switch will initiate radio transmissions of the headset plugged into the headset module where the foot switch is installed.

The foot switch is installed to the headset module using a CA cable and RJ-12 connector. You will need to open the headset module and remove the plastic tab which covers the access hole to the second modular jack.



**Warning**  
The CA cable from the intercom should always be plugged into the headset module on the “Firecom” label side.

## SYSTEM WIRING

### Radio Connections

The mobile radio is connected to the intercom by using the radio port on the back of the unit. A MR interface cable, with an un-terminated end, is supplied with the intercom. For independent wire descriptions, see Appendix A.



#### Warning

To ensure proper operation, the connection to the radio should be performed by a qualified radio technician.

Some radio specific interface cables are available for common model radios. For a list of interface cables, please visit [www.firecom.com](http://www.firecom.com) and click on the Product Support section of our web site or contact our service department at 800-527-0555.

When installing an MR cable, tighten the two screws on the plug of the cable.



#### Warning

If the screws are not properly tightened, the 9-pin plug may vibrate and cause problems with transmission, reception, or other radio functionality.

## SETTINGS

Side View

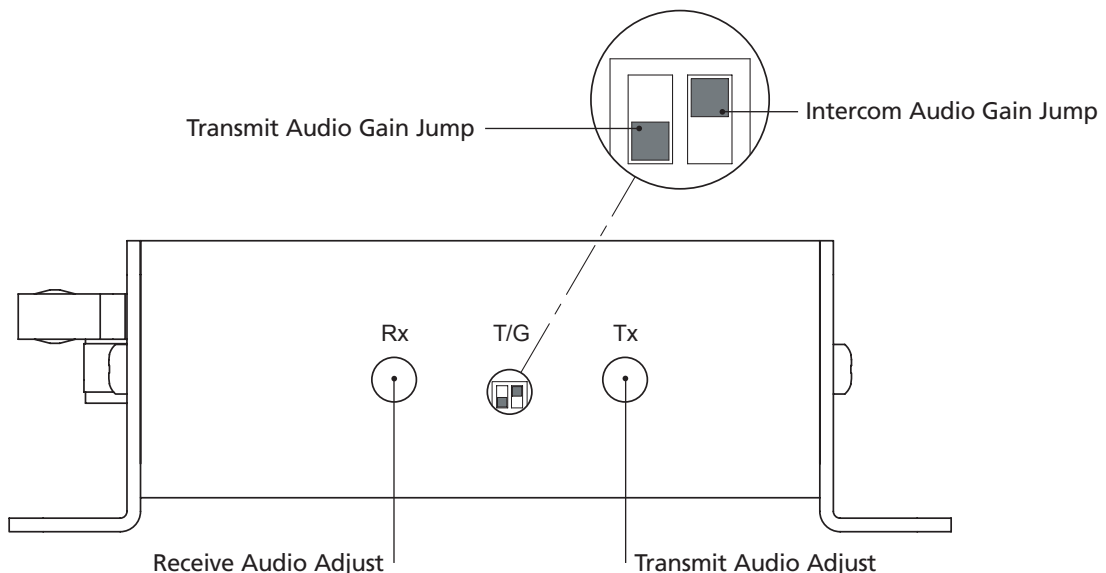

Several adjustments to the 110 Radio Interface are required. When connecting to the mobile radio, it will be necessary to make both transmit and receive audio adjustments.



#### Warning

These adjustments must be performed by a qualified radio technician. Failure to perform these adjustments may result in problems hearing or transmitting radio signals when using the intercom system.

## SETTINGS

### **RX**

The receive audio adjustment is a rotational adjustment of the audio gain from the radio. When making this adjustment, set your mobile radio volume to the normal volume level used without the 110 interface installed. The audio level should be adjusted with the headset user for quality audio mixing.

### **Transmit Audio Gain Jump**

The transmit audio gain jump switch is an incremental gain increase of the audio broadcast through the radio. The gain is increased when the switch is in the “up” position and decreased in the “down” position. The transmit audio “TX” should be used initially for adjustment and the transmit audio gain jump used only if required.

### **Headset Audio Gain Jump**

The headset audio gain jump switch is an incremental gain increase of the headset sound level. The headset is also equipped with an independent volume control. If an overall higher headset sound level is desired, the headset audio gain jump switch may be used. The gain is increased when the switch is in the “up” position and decreased in the “down” position.

### **TX**

The transmit audio adjustment is a rotational adjustment of the audio broadcast through the radio. Adjust the radio transmit sound level to eliminate clipping and provide quality audio mixing.

After these adjustments are made, the holes may be sealed using plugs (provided).

## OPERATION

The 110 radio interface is designed to offer clear communications to a mobile radio using a noise-canceling headset.

Before testing the unit, make sure the power supplied to the unit and the radio is turned on. To begin using the radio interface, plug your Firecom headset into the headset module. For proper headset fitting instructions, as well as care and maintenance, see your headset manual.

Firecom offers both over-the-head and under-the-helmet styles of headsets for use with the 110 radio interface. These radio transmit headsets are identified by a red momentary PTT button on the headset. To transmit out the radio, press and hold the red PTT button. You will hear your voice in the headset only when you transmit. You will always hear radio traffic on your headset. Volume is adjusted on the ear dome.

### **Foot Switch (optional)**

If an optional foot switch is installed, the headset plugged into the headset module will transmit over the radio when the foot switch is activated. See **System Wiring** section, “**Foot Switch (optional)**” in this manual.

## TROUBLESHOOTING

If the radio interface system does not operate as expected, check the following items:

- Check for power at the unit and confirm that the fuse is not blown or the circuit breaker is not tripped.
- Confirm that a dedicated ground is used for the interface power and not a chassis ground.
- Check for corrosion on headset plug.
- Check that the headset is plugged in all the way.
- Check headset controls.

If these steps do not correct the problem, review the chart below for symptoms and recommendations.

SYMPTOM	RECOMMENDED SOLUTION
Intermittent crackling in headset speakers	<ul style="list-style-type: none"> <li>• Check the headset plug. Make sure it is clean for good electrical contact.</li> <li>• Check wire connections at the headset module.</li> <li>• Check wire connections at the radio interface unit.</li> <li>• Check the CA cable and RJ-12 connectors.</li> </ul> <p><b>Tip:</b> Determine if the problem is with the headset or the system by plugging a different headset (if available) into the headset module and retesting.</p>
Alternator whine and other source distracting noises	<ul style="list-style-type: none"> <li>• Connect both the radio interface and radio to the cleanest power source possible, without sirens, strobes, flashers, and motors (i.e. wipers, heater, etc.).</li> <li>• Check the power and ground connections for both the radio interface and the radio. Make sure they are clean and tight.</li> <li>• Ensure that power and ground wires for the radio and radio interface are no smaller than 18 AWG.</li> <li>• Check MR cable for proper wiring connections.</li> <li>• Make sure that all battery connections are clean and free from dirt and corrosion.</li> <li>• Use separate noise filters on radio and/or radio interface power as needed.</li> <li>• Use a robust common ground for both the radio and the radio interface.</li> </ul> <p><b>Tip:</b> Check the power to the unit for an AC signal. There should be less than 300mVAC present on power lines</p>
No sound in headset speakers	<ul style="list-style-type: none"> <li>• Check the volume control on the headset.</li> <li>• Confirm the radio is operating properly.</li> <li>• Check the headset plug. Make sure it is clean for the best electrical contact.</li> <li>• Confirm that the radio interface has adequate power.</li> <li>• Check wire connections at the headset module.</li> <li>• Check the MR cable between the radio and interface unit. Make sure the screws on the 9-pin D-sub connector are tight. See <b>Appendix A</b> for wiring.</li> <li>• Check the CA cable and RJ-12 connector installation.</li> </ul> <p><b>Tip:</b> Determine if the problem is with the headset or the system by plugging a different headset (if available) into the headset module and retesting.</p>

## TROUBLESHOOTING

The radio transmitted audio is weak  
or  
The radio keys but no audio is transmitted  
or  
You can hear the radio, but radio users cannot hear you

- Confirm that you have the headset microphone close to your mouth, within 1/8 inch is recommended.
- Adjust the transmit audio setting –see Settings.
- Confirm that you have a radio transmit headset with a red PTT button.
- Check the MR cable between the radio and the interface unit. Make sure the screws on the 9-pin D-sub connector are tight. See **Appendix A** for wire connection details.
- Check the headset plug. Make sure it is clean for the best electrical contact.
- Check wire connections at the headset module.
- Check wire connections at the interface unit.
- Check the CA cable and RJ-12 connector installation.

**Tip:** Determine if the problem is with the headset or the system by plugging a different headset (if available) into the headset module and retesting.

**Tip:** Substituting suspect components in the system may be helpful in tracking down problems.

Radio receive audio is weak  
or  
You can't hear the radio, but radio users can hear you

- Check the radio volume.
- Adjust the receive audio setting. See the **Settings** section in this manual.
- Verify that receive audio is present by listening to the radio's speaker.
- Check the headset volume control setting.
- Check the headset plug. Make sure it is clean for the best electrical contact.
- Check wire connections at the headset module.
- Check wire connections at the interface unit.
- Check the CA cable and RJ-12 connector installation.
- Check the MR cable between the radio and the interface unit. Make sure the screws on the 9-pin D-sub connector are tight. See **Appendix A** for wire connection details.

**Tip:** Determine if the problem is with the headset or the system by plugging a different headset (if available) into the headset module and retesting.

**Tip:** Substituting suspect components in the system may be helpful in tracking down problems.

The radio doesn't key

- Confirm that you have a radio transmit headset with a red PTT button.
- Check the CA cable and RJ-12 connector installation.
- Check the MR cable between the radio and the interface unit. Make sure the screws on the 9-pin D-sub connector are tight. See **Appendix A** for wire connection details.

**Tip:** Determine if the problem is with the headset or the system by plugging a different headset (if available) into the headset module and retesting.

**Tip:** Substituting suspect components in the system may be helpful in tracking down problems.

If a problem persists in a headset or intercom unit, contact Firecom for a Return Merchandise Authorization (RMA) number. Return the headset or intercom for replacement or repair.

Contact:

**Firecom Corporation**  
7340 SW Durham Road  
Portland, OR 97224 USA  
800-527-0555 OR 503-684-6647

## OPTIONS AND ACCESSORIES

See [www.firecom.com](http://www.firecom.com) for options and accessories.

## SPECIFICATIONS

**Dimensions:**

L x H x W: 4.16 [106] x 2.75 [70] x 1.29 [33] inches [millimeters]

**Weight:**

5.9 oz [170 g] (without cables)

**Power Requirements:**

Minimum: 9.5 VDC @ 83mA

Maximum: 28.0 VDC @120mA

Fuse: 2 amp

See the headset manual for headset specifications.

## Appendix A - Wiring Diagrams

### 5 Conductor Plug

5 Conductor Plug

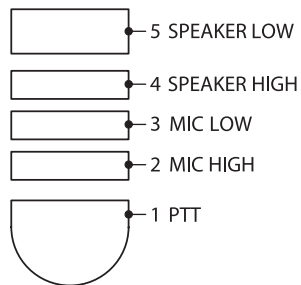

### HM-10 Headset Module

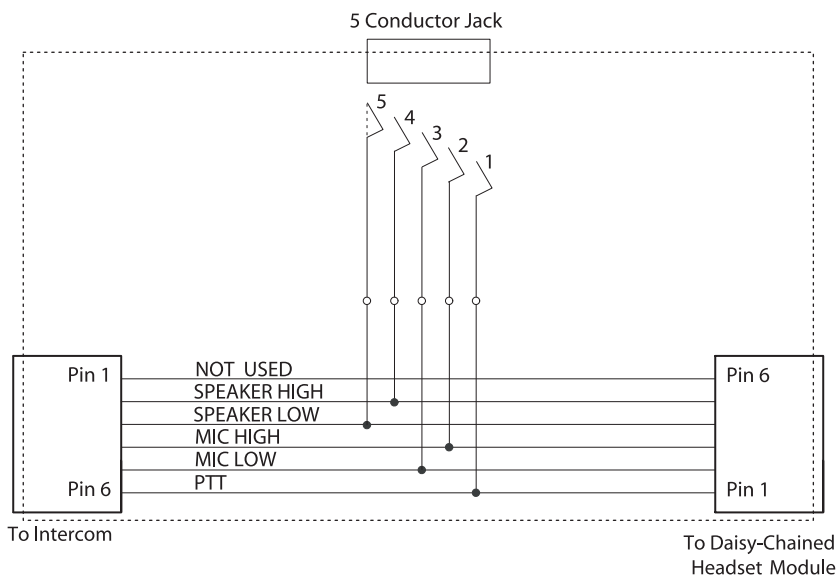

## Appendix A - Wiring Diagrams

### PP-20

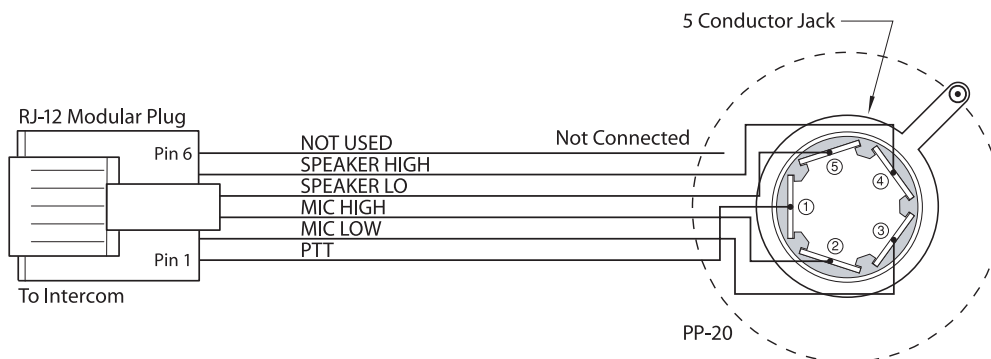

### CA Cable

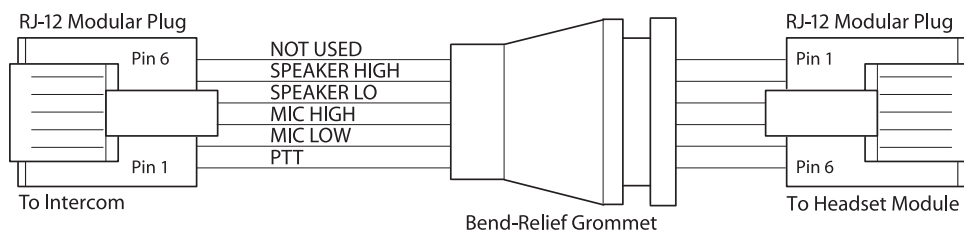

### Mobile Radio Interface Cable

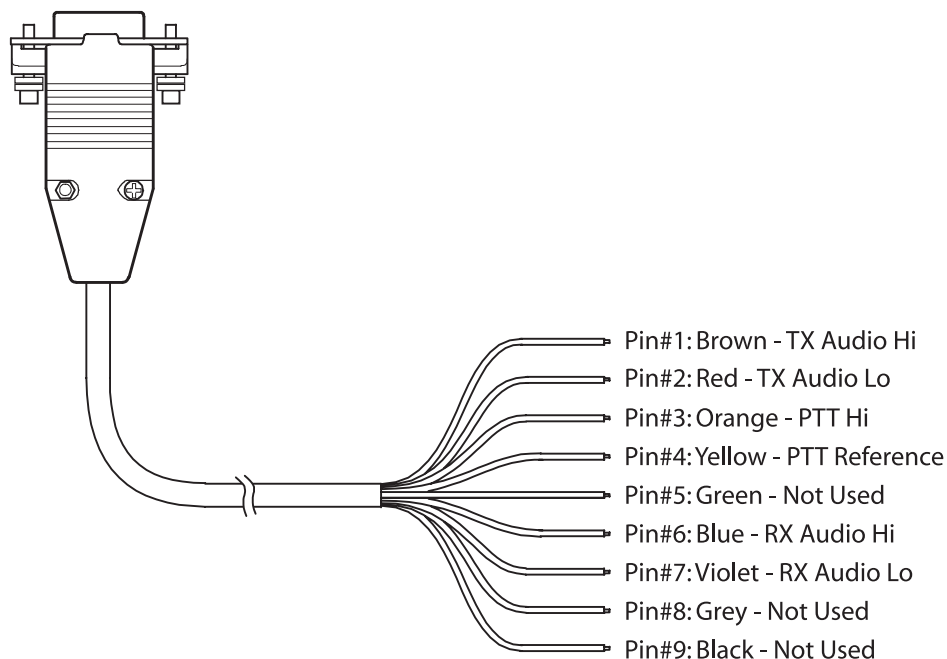

## Appendix B - RJ-12 Connector Assembly

### RJ Connector, 6 Position Plug Installation

To install the RJ-12 connector plug onto the flat CA cable:

1. Using the cutter blade on the crimping tool (labeled A, in figure 1), cut the CA cable so the cut is clean and at a 90-degree angle to the side of the cable.
2. Fully insert one end of the CA cable between the stripping blades (labeled C, in figure 1) until the end of the cable hits the stop (labeled B, in figure 1).

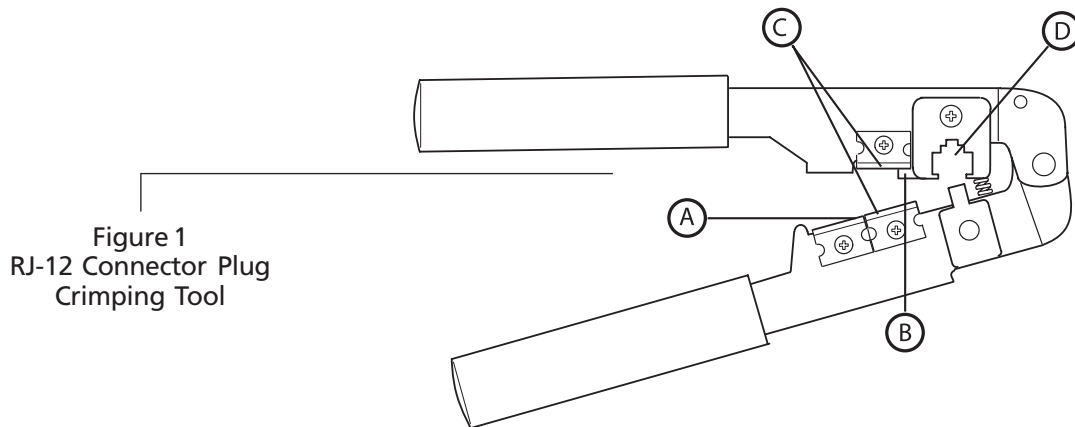

Figure 1  
RJ-12 Connector Plug  
Crimping Tool

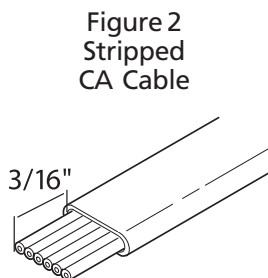

Figure 2  
Stripped  
CA Cable

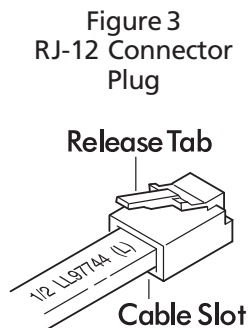

Figure 3  
RJ-12 Connector  
Plug

3. Squeeze the handles of the crimping tool together until the tool bottoms out.
4. While holding the handles together, pull the cable out of the tool.
5. The stripped insulation should expose approximately 3/16" of wire (figure 2).
6. Push a RJ-12 connector into the plug holder on the crimping tool (labeled D, in figure 1) until the release tab on the plug locks into position.
7. Holding the cable so that the printed side of the cable is toward the release tab on the plug, push the cable into the plug as far as it will go.

**Note: Always make sure the printed side of the cable is facing the release tab on the RJ-12 connector plug (figure 3). This ensures proper orientation of the plug on each end of the cable.**

8. Squeeze the tool handles completely together. You may feel the crimper finish punching the contacts through the insulation on the wires.
9. Let the handles spring open.
10. Push down on RJ-12 connector release tab (figure 3) and remove the RJ-12 connector from the crimping tool.
11. Inspect the plug to ensure that the cable is held securely in place.
12. Repeat this procedure as necessary to install a RJ-12 connector plug on each end of each CA cable.

## WARRANTY

### Two-Year Limited Warranty to the Original Purchaser

Sonetics Corporation warrants to the original purchaser of its products, that they will be free from defects in materials and workmanship, under normal and proper use, for the period of two years from date of purchase. Sonetics Corporation will repair or replace, at its option, any parts showing factory defects during this warranty period, subject to the following provisions. This warranty applies only to a new product which has been sold through authorized channels of distribution. All work under warranty must be performed by Sonetics Corporation. All returned products must be shipped to our address, freight prepaid, accompanied by a dated proof of purchase. The purchaser voids this warranty if he, she or others attempt to repair, service or alter the product in any way. This warranty does not apply in the event of accident, abuse, improper installation, unauthorized repair, tampering, modification, fire, flood, collision, or other damage from external sources, including damage which is caused by user replaceable parts (leaking batteries, etc.). This warranty does not extend to any other equipment or apparatus to which this product may be attached or connected. The foregoing is your sole remedy for failure in service or defects. Sonetics Corporation shall not be liable under this or any implied warranty for incidental or consequential damages, nor for any installation or removal costs or other service fees. This warranty is in lieu of all other warranties, express or implied, including the warranty of merchantability or fitness of use, which are hereby excluded. To the extent that this exclusion is not legally enforceable, the duration of such implied warranties shall be limited to two years from date of purchase. No suit for breach of express or implied warranty may be brought after two years from date of purchase.







**FIRECOM IS A DIVISION OF SONETICS CORPORATION**

7340 SW Durham Road, Portland, OR 97224 USA • 800-527-0555 • 503-684-8229 • Fax: 503-620-2943  
e-mail: [sales@firecom.net](mailto:sales@firecom.net) • [www.firecom.com](http://www.firecom.com)

Copyright ©2007 Sonetics Corporation - All rights reserved.  
The information in this document is subject to change without notice.  
No part of this document may be reproduced in any form without prior written consent of Sonetics Corporation.  
This document is part number 600-0073-00 RevA. Printed in U.S.A